

Data sheet

Document number: DB-KU-100097-5

Creation date: Juli 2022



Flow sensor FLT-M1_i1 | FLT-M1_i1a

Version DN01



Inhalt

General information on the

Data sheet	3
Safety instructions	3
Product specification	4
Product specification	5



General information on the data sheet

Usage and storage

- This data sheet is an integral part of the flow sensor.
- Keep the data sheet in the immediate vicinity of the place of use.
- If the flow sensor is passed on to a third party, pass on the data sheet or the relevant contents to the third party along with it.
- Read the data sheet carefully.
- We reserve the right to make changes.

Function

The data sheet provides information on the safe use and installation of the flow sensor.

Safety instructions

Designated use

- The flow sensor is to be used exclusively for flow measurement of liquids and gases within the scope of the product specification.
- Failure to observe the range of application may impair safety. The manufacturer is not liable for damage resulting from improper use.

Requirements for personnel

The flow sensor may only be installed by qualified personnel.

Product safety

The flow sensor is intended to act as an electronic component for integration into a device or system. The flow sensor is not a stand-alone measuring device and therefore does not require the CE mark to be affixed.

Operational reliability

- The system builder or device manufacturer is responsible for safe integration into a system or device.
- The operator is responsible for trouble-free operation of the flow sensor.
- Only operate the flow sensor if it is in perfect technical condition and is performing reliably.
- If the medium temperature is high, ensure that the sensor is protected against accidental contact in order to avoid burns.
- Unauthorized modifications or repairs to the flow sensor are not permitted and can lead to unforeseeable dangers.



Product description

Overview

The FLT-M1 flow sensor has been designed to determine the mass flow of liquids and gases. This is done with a mini Coriolis measuring system with an S-shaped measuring tube and a temperature sensor.

The flow sensor is installed directly in a flow pipe via a manufacturer-specific connection. If medium flows through the flow sensor, the measured value information is generated with the aid of Coriolis forces. The measured values are fed to the higher-level system via an I2C bus or Modbus TTL.

It is possible to take flow measurements for pressure lines up to 100 bar at a measuring rate of 200 Hz (200 measured values per second). Flow changes are recorded with a step response time of 50 ms.

Mini Coriolis measuring system

The heart of the mini Coriolis measuring system is a vibrating S-shaped measuring tube with a small diameter. Several sensors are located on the measuring tube for vibration generation and sensor signal acquisition purposes; these sensors are arranged in a way that is designed to achieve the best possible results. The temperature at the measuring tube is recorded to com-

pensate for temperature effects. The measuring tube is mounted on a plate which dampens vibrations from the outside. In addition, a compact and hermetically sealed metal housing protects the measuring system from further interference.

Flow measurement

The mass flow is determined using the Coriolis force. The Coriolis force acts on a liquid flowing through a vibrating tube. In the process, it causes a change in the vibration of the tube. The change in the vibration of the tube is proportional to the mass flow.

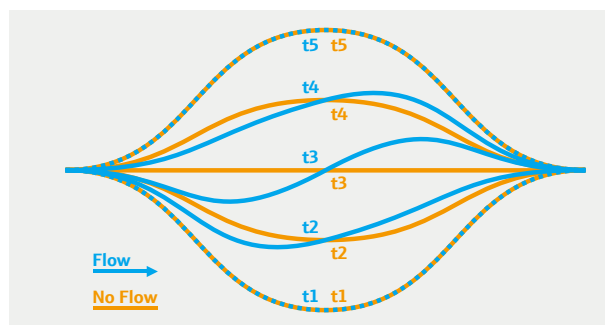

Change in pipe vibration due to Coriolis force

Two vibration sensors attached to the measuring tube detect the change. These signals are evaluated by the electronics and made available as the mass flow. The

volume flow can also be calculated using the mass flow information and the density calculation.

Density measurement

For the density measurement, the flow sensor analyzes the resulting natural frequency of the vibrating, filled measuring tube. The resulting natural frequency of the measuring tube depends on the mass and thus on the density of the medium in the measuring tube: the greater the medium density, the lower the natural frequency. The natural frequency is therefore a function of the medium density.

Possible applications

The flow sensor can be used in combination with a pump and/or a valve as a mass flow controller.



Product design

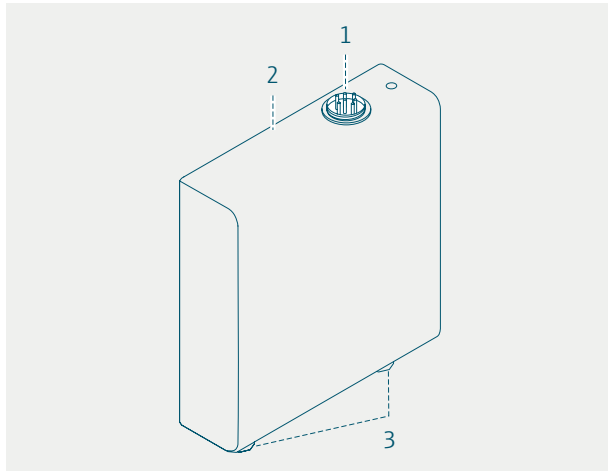

Product design Flow Sensor FLT-M1

1 Electrical interface: solder pins, 7-pole

2 Hermetically sealed housing

3 Fluid interface: manufacturer-specific connection, DN 1

Product identification

The flow sensor is identified by a consecutive 11-digit serial number. This is mounted on the outside of the housing.

Product specification

General information

Measured values	<ul style="list-style-type: none"> ■ Mass flow ■ Density ■ Temperature
------------------------	---

Units of measurement	Adjustable
-----------------------------	------------

Measurement performance

Max. measurement error*	<ul style="list-style-type: none"> ■ Mass flow: $\pm 0.10\%$ o.r. ■ Zero-point stability of mass flow: ± 0.0007 kg/h ■ Max. deviation of mass flow: $\pm 0.10\%$ or ± 0.0007 kg/h ■ Density: ± 5 kg/m³ ■ Temperature: ± 1.0 K
--------------------------------	---

Repeatability	<ul style="list-style-type: none"> ■ Mass flow: $\pm 0.05\%$ o.r. ■ Zero-point stability of mass flow: ± 0.00035 kg/h ■ Max. deviation of mass flow: $\pm 0.05\%$ or ± 0.00035 kg/h ■ Density: ± 2.5 kg/m³ ■ Temperature: ± 0.5 K
----------------------	---

Measuring rate	200 Hz
-----------------------	--------

Step response time	50 ms
---------------------------	-------

*Valid under reference condition (see calibration protocol)

Temperature conditions

Permitted medium temperature	-10...+70 °C
-------------------------------------	--------------

Permitted ambient temperature	-10...+80 °C
--------------------------------------	--------------

Permitted storage temperature	-20...+85 °C
--------------------------------------	--------------

Range of application

Recommended flow measuring range	0...30 kg/h
	Pressure loss as a function of flow rate, see pressure loss curve on page 6.

Permitted medium pressure	Max. 100 bar (rel.)
----------------------------------	---------------------

Inlet and outlet sections	Inlet and outlet distances have no influence on the measuring accuracy.
----------------------------------	---

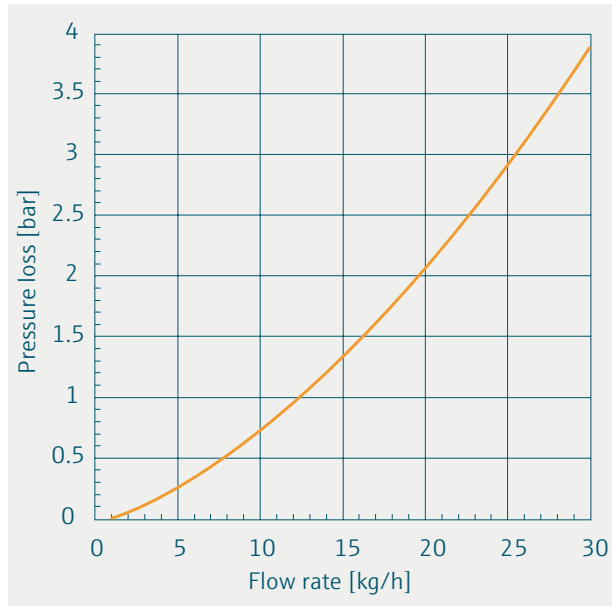

Pressure loss curve for water

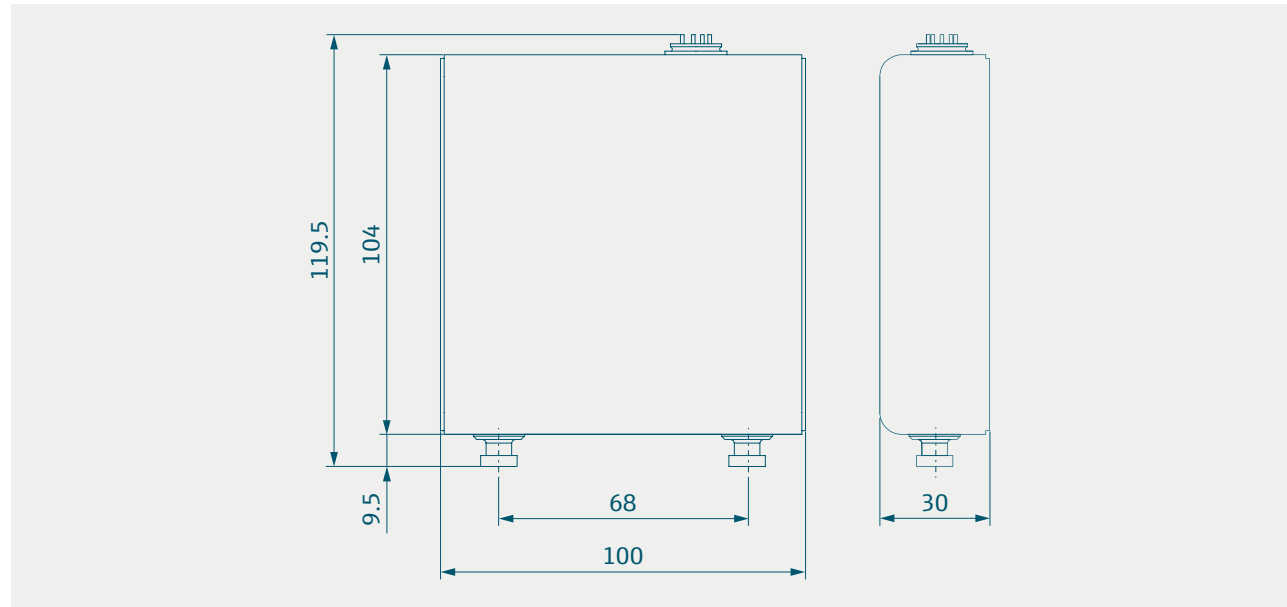

Design, dimensions in mm

Environmental conditions

Climate class	Not specified
Electromagnetic compatibility	Prepared for EMC 2014/30/EU (EN 61326-1)
Vibration and shock resistance	Prepared for the following standards: <ul style="list-style-type: none"> ▪ IEC/EN 60068-2-6 ▪ IEC/EN 60068-2-27 ▪ IEC/EN 60068-2-31 ▪ IEC/EN 60068-2-64
Degree of protection	Housing is hermetically sealed, IP protection only when installed.

Dimensions

Dimensions	100 × 30 × 104 mm ³
Weight	850 g
Inner diameter of measuring tube	1.1 mm

Materials

Housing	<ul style="list-style-type: none"> ▪ Stainless steel, 1.4301 (304L)
Wetted parts	<ul style="list-style-type: none"> ▪ Stainless steel, 1.4404/1.4435 (316L) ▪ Option: Alloy C22, 2.4602

Electrical interfaces

Connection	Solder pins with 1 mm diameter, 7-pole
Communication	Ordering options: <ul style="list-style-type: none"> ▪ Modbus TTL
Power supply	DC 10...35 V (max. 1 Watt) No galvanic isolation

For write operations, the write times to internal memory elements must be observed. I.e. the power supply must be guaranteed for the entire duration of the write operation (e.g. 50 ms for a 4-byte FLOAT32 value).

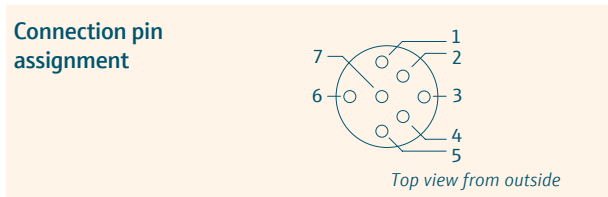

Pin	Assignment	Modbus TTL
1	V+	Supply voltage
2	SDA	Modbus Tx
3	SCL	Modbus Rx
4	NC	Modbus T/R
5	CDI-Rx	Serial reception (service interface)
6	CDI-Tx	Serial transmission (service interface)
7	GND	Reference potential for all circuits

General settings:

Baudrate	19200 BAUD
Data transfer mode	RTU
Data bits	8
Parity	Even
Byte order	1-0-3-2
Stop bits	1 bit
Modbus Slave Address	247
Transmission type	Modbus RTU (Protocol)

Temperature unit	°C
Pressure unit	bar
Density unit	kg/l
Mass flow unit	kg/h
Mass unit	kg
Volume flow unit	l/h
Volume unit	m ³
Flow damping	0 [s]
Temperature damping	0 [s]
Pressure damping	0 [s]
Density damping	0 [s]
Reference temperature unit	°C
Reference temperature	0 [°C]
Reference pressure unit	bar
Reference pressure	1.01325 [bar]
Assign diagnostic behavior	Alarm
Failure mode	NaN value
Interpreter mode	Standard
Zero point adjustment control	Cancel

Flow override	Off
Assign process variable	Mass flow
Installation direction	Flow in arrow direction

Modbus RTU register information with read/write access:

Name	Address	Data type	Selection/ Input
Modbus Slave Address	4909	UINT16	1...247
Baudrate	4911	ENUM UINT16	0: 1200 1: 2400 2: 4800 3: 9600 4: 19200 5: 38400 6: 57600 7: 115200
Data transfer mode	4912	ENUM UINT16	0: RTU 1: ASCII
Parity	4913	ENUM UINT16	0: Even / 1 stop bit 1: Odd / 1 stop bit 2: None / 2 stop bits 3: None / 1 stop bit
Byte order	4914	ENUM UINT16	0: 0-1-2-3 1: 3-2-1-0 2: 2-3-0-1 3: 1-0-3-2



Telegram delay	4915	FLOAT32	0...100
Assign diagnostic behavior	4920	ENUM UINT16	0: Off 1: Warning 2: Alarm 3: Alarm or warning
Failure mode	4919	ENUM UINT16	0: NaN value 1: Last valid value
Interpreter mode	4924	ENUM UINT16	0: Standard 1: Ignore surplus bytes
Access code	2176	UINT16	0...9999
Mass flow unit	2100	ENUM UINT16	0: g/s 1: g/min 2: g/h 3: g/d 4: kg/s 5: kg/min 6: kg/h 7: kg/d 8: t/s 9: t/min 10: t/h 11: t/d 12: oz/s 13: oz/min 14: oz/h 15: oz/d 16: lb/s 17: lb/min 18: lb/h 19: lb/d 20: STon/s

Mass flow unit (continued)			21: STon/min 22: STon/h 23: STon/d 24: User mass/s 25: User mass/min 26: User mass/h 27: User mass/d
Mass unit	2101	ENUM UINT16	0: g 1: kg 2: t 3: oz 4: lb 5: STon 6: User mass
Volume flow unit	2102	ENUM UINT16	0: cm ³ /s 1: cm ³ /min 2: cm ³ /h 3: cm ³ /d 4: dm ³ /s 5: dm ³ /min 6: dm ³ /h 7: dm ³ /d 8: m ³ /s 9: m ³ /min 10: m ³ /h 11: m ³ /d 12: ml/s 13: ml/min 14: ml/h 15: ml/d 16: l/s 17: l/min

Volume flow unit (continued)			18: l/h 19: l/d 20: hl/s 21: hl/min 22: hl/h 23: hl/d 24: Ml/s 25: Ml/min 26: Ml/h 27: Ml/d
Volume unit	2103	ENUM UINT16	0: cm ³ 1: dm ³ 2: m ³ 3: ml 4: l 5: hl 6: Ml Mega 8: af 9: cf 10: fl oz (us) 11: gal (us) 12: Mgal (us) 13: bbl (us;liq.) 14: bbl (us;beer) 15: bbl (us;oil) 16: bbl (us;tank) 17: gal (imp) 18: Mgal (imp) 20: bbl (imp;oil) 21: User vol. 22: kgal



Density unit	2106	ENUM UINT16	0: g/cm ³ 2: kg/dm ³ 3: kg/l 4: kg/m ³ 5: SD4°C 6: SD15°C 7: SD20°C 8: SG4°C 9: SG15°C 10: SG20°C 11: lb/cf 12: lb/gal (us) 13: lb/bbl (us;liq.) 14: lb/bbl (us;beer) 15: lb/bbl (us;oil) 16: lb/bbl (us;tank) 17: lb/gal (imp) 18: lb/bbl (imp;beer) 19: lb/bbl (imp;oil) 20: User dens. 21: g/m ³ 22: g/ml
Temperature unit	2108	ENUM UINT16	0: °C 1: K 2: °F 3: °R

Pressure unit	2129	ENUM UINT16	0: bar 1: psi a 2: bar g 3: psi g 4: Pa a 5: kPa a 6: MPa a 7: Pa g 8: kPa g 9: MPa g 10: User pres
Zero point adjustment control	5120	ENUM UINT16	0: Cancel 1: Start 2: Zero point adjust failure 8: Busy
Flow damping	5509	FLOAT32	0...100.0
Density damping	5507	FLOAT32	0...999.9
Temperature damping	5126	FLOAT32	0...999.9
Flow override	5502	ENUM UINT16	0: Off 1: On
Assign process variable	5100	ENUM UINT16	0: Off 1: Mass flow 2: Volume flow 3: Corrected volume flow
On value low flow cutoff	5137	FLOAT32	

Off value low flow cutoff	5103	FLOAT32	
Pressure shock suppression	5139	FLOAT32	
Installation direction	5500	ENUM UINT16	0: Flow in arrow direction 1: Flow against arrow direction
Zero point adjustment control	5120	ENUM UINT16	0: Cancel 1: Start 2: Zero point adjust failure 8: Busy

ZP progress corresponds to progress in % (0-99)

Modbus RTU register information with read access:

Name	Adress	Data type	Selection/ Input
Mass Flow	2006	FLOAT32	
Volume flow	2008	FLOAT32	
Corrected volume flow	2010	FLOAT32	
Density	2012	FLOAT32	
Reference density	2014	FLOAT32	
Temperature	2016	FLOAT32	



Fluidic interface

Fluidic interfaces Manufacturer-specific connection.

Certificates and approvals

CE mark The flow sensor is intended to act as an electronic component for integration into a device or system. The flow sensor is not a stand-alone measuring device and therefore does not require the CE mark to be affixed.

RoHS All installed components meet the requirements of the RoHS Directive.

Zero point adjustment

Zero point adjustment A zeropoint adjust in the application is based on factory calibration and due to excellent zeropoint stability not required in general. However under certain circumstances a zeropoint adjust can be recommended:

- When highest accuracy is needed at low flow rates.
- When process conditions are extreme, e.g. very high process temperature.

For a zeropoint adjust the following pre-conditions need to be fulfilled:

Zero point adjustment (continued)

- Measuring line is completely shut off, i.e. real flow is truly zero!
- Measuring tube is filled homogeneously and pressurized with at least 15 psi (gauge) to avoid gas bubbles in the fluid, when measuring gas no condensation is allowed.

During the zeropoint adjust stability of measured flow rate is monitored and its mean value is built for new zeropoint value. This typ. takes 20 s. If the process conditions are not suitable zeropoint adjust is aborted and old zeropoint value remains valid.

Flow damping

Flow damping With this time constant (PT1 system) mass flow value can be damped.

Factory default is 0 s (no dampening). This dampening increases system reaction (step response time) time on the other hand.

Especially for flow control application this should be considered. E.g. a time constant of 0.1 s leads to an increase of step response time from 50 ms to 550 ms.

Low Flow Cutoff

Low Flow Cutoff With this function mass flow value is cut off to zero, when threshold is underrun.

So it's ensured that totalizer is stopped properly and cannot creep away.

Low flow cutoff is left when mass flow overruns 150% of set threshold (hysteresis).

When low flow cutoff is active no status message is set.

Factory default: 0.08 kg/h

Empty Pipe Detection

Empty Pipe Detection With this function an empty or partly filled measuring tube is detected. When density underruns set threshold

mass flow is set to zero and a status message is set correspondingly.

Factory default: 0.2 kg/l

